

REV	RELEASE	DESCRIPTION	APPR	DATE
A	NEW	INITIAL RELEASE	PD	6/5/20

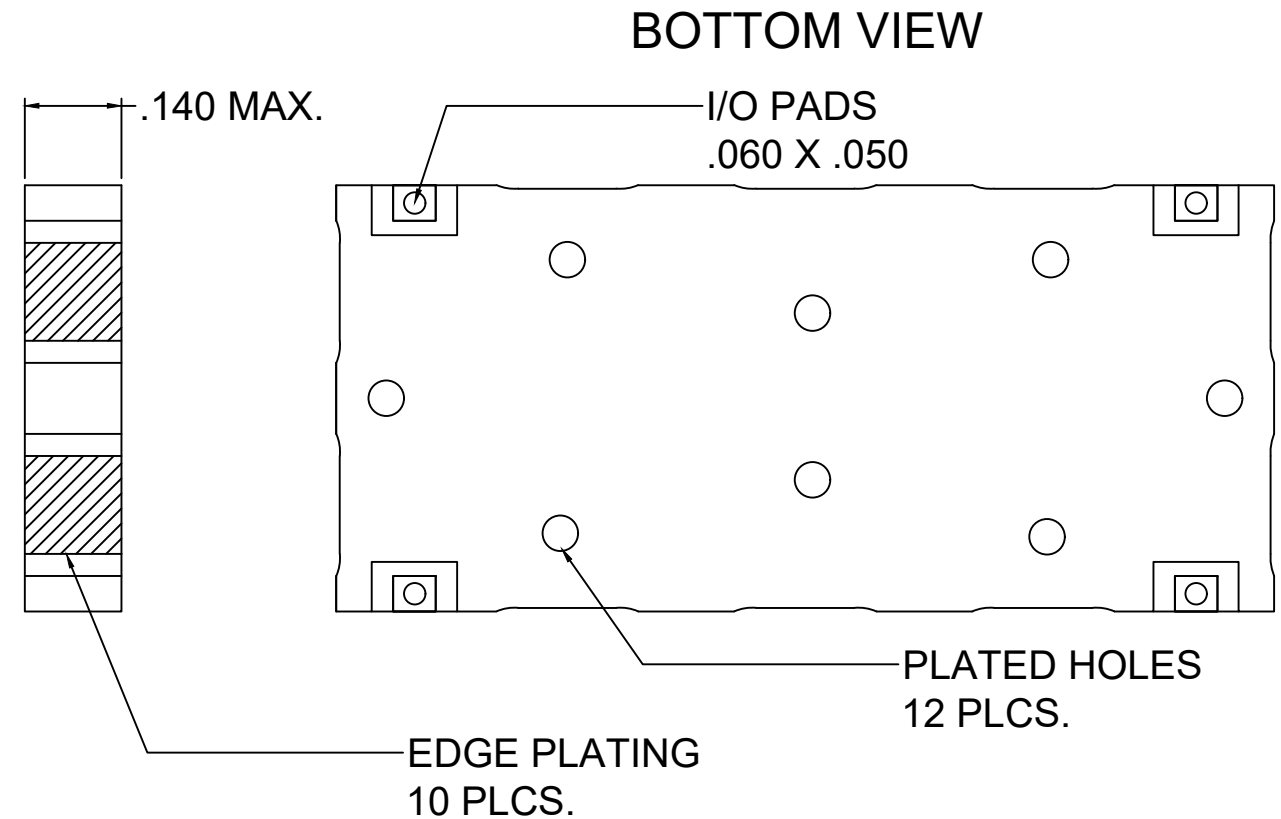
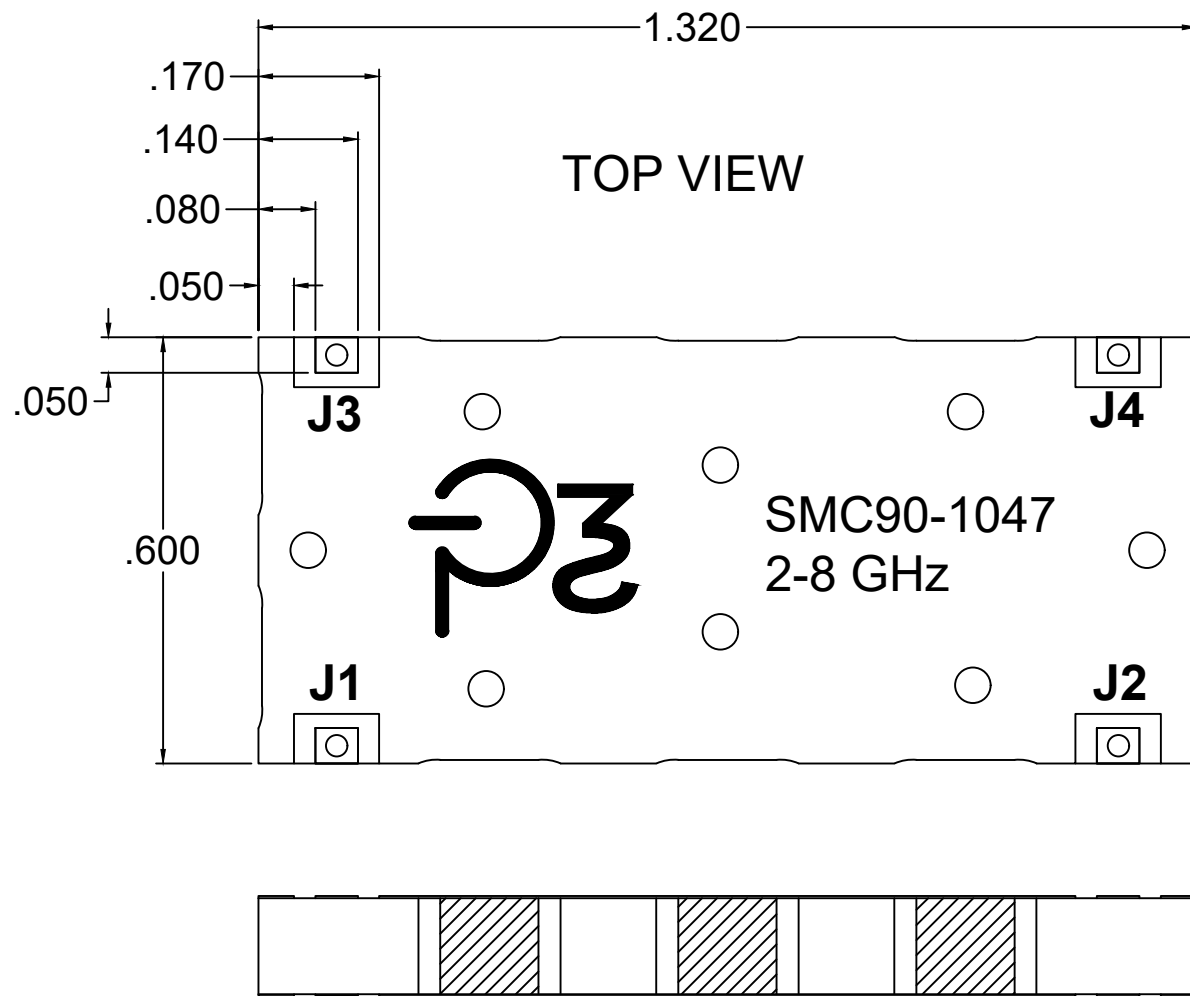

**PORT CONFIGURATION**

PORTS	J1	J2	J3	J4
J1	--	ISO	0°	-90°
J2	ISO	--	-90°	-0°
J3	0°	-90 0°	--	ISO
J4	-90°	0°	-ISO	--

**SPECIFICATIONS:**

Frequency: 2.0 - 8.0 GHz.  
 Power: 200 Watts CW  
 Insertion Loss: 0.80 dB Max.  
 Isolation: 15 dB Min.  
 Phase Bal.: 90° ±5.0° Max.  
 VSWR: 1.4:1 Max.  
 Amplitude Bal.: ±0.7 dB Max.  
 Oper. Temp.: -55° to +85°C

**MECHANICAL:**

Finish: Non-Magnetic, Imersion Tin Plate  
 Marking: P/N to be half etched



**PREFERRED  
 POWER PRODUCTS**  
 PALM CITY, FLORIDA 34990

UNLESS OTHERWISE SPECIFIED  
 ALL DIMENSIONS ARE IN INCHES

**TOLERANCES:**

DECIMALS	ANGULAR
.X ± .1	± .5°
.XX ± .01	
.XXX ± .005	

THIS DRAWING AND ALL CONTENTS  
 HEREIN, ARE THE SOLE, PROPRIETARY  
 PROPERTY OF PREFERRED POWER  
 PRODUCTS, LLC AND MAY NOT BE USED,  
 REPRODUCED OR DISCLOSED WITHOUT  
 EXPRESSED WRITTEN CONSENT.

PART NO.

**SMC90-1047**

**HYBRID COUPLER, SMT**  
**2.0 - 8.0 GHz.**  
**200 WATT**

CHECKED	PD	6/5/20	APPROVED	PD	6/5/20
DRAWN	PD	6/5/20	ENGINEER	PD	6/5/20

CAGE CODE 7W5T7 SCALE 1:1 SHEET 1 OF 1